

Beta

2023



NEW ITEMS

**PROMOTION VALID FROM 04/09/2023
TO 29/02/2024**

Prices do not include V.A.T.



We at Beta keep investing in Italian-made production and are proud to

THE NEW WORKSHOP EQUIPMENT RANGE, RSC50

Based on the expertise acquired with the two existing workshop equipment ranges, RSC55 and C45PRO, which allowed us to listen to and fully understand professional users' requirements, the project for the new range, RSC50, relies on the following pivotal concepts:



• **QUALITY**

Our acclaimed care in choosing the materials, painstaking attention for detail and, last but not least, the captivating design make the RSC50 a one-of-a-kind workshop equipment range.



• **FUNCTIONALITY AND STURDINESS**

The 63-cm-deep worktop means having a large, convenient, functional work surface available. It can be fitted with a vice, thereby allowing heavy-duty jobs to be carried out.

• **EFFICIENCY**

Simple, quick installation, based on the optimized production of the various parts of the range.

• **FLEXIBILITY**

Each workshop equipment combination can be extended or modified at any time as required.

• **COMPATIBILITY**

The drawers in Beta's standard dimensions (588x367 mm) can accommodate the numerous tool modules, which are available in both soft and hard versions, made from EVA and ABS respectively.



The new workshop equipment range, RSC50, comprises preassembled combinations, developed by Beta for professionals; alternatively, you can design your workplace on your own, choosing from many under-bench modules, wall-mounted cabinets and furnishing accessories. The customized colours of the drawer handles and lights under the worktops and wall-mounted cabinets result in unique workshop equipment, thus making the RSC50 an ideal choice for those who prioritize working in a functional, efficient environment.

050001045 **RSC50 I**
~~£ 20,910.00~~ **£ 10,460.00**

Workshop equipment combination RSC50

Combination comprising:

- 1 2.240 mm worktop (RSC50 PG/3-2,2MT)
- 1 1.495 mm worktop (RSC50 PG/2-1,5MT)
- 1 fixed module with 7 drawers (RSC50 M7)
- 1 mobile roller cab with 7 drawers (RSC50 C7)
- 1 fixed service module with 2 drawers (RSC50 MS-2C)
- 1 self-supporting complete corner (RSC50 AC-G)

- 1 fixed module with 5 drawers (RSC50 M5)
- 1 fixed two-door module (RSC50 MA)
- 5 wall-mounted cabinets (RSC50 PM)
- 5 upper perforated tool panels (RSC50 PFS)
- 5 lower perforated tool panels (RSC50 PFI)
- 5 pairs of right/left uprights (RSC50 P/2MDX-SX)
- 2 single-door cabinets (RSC50 A1)



050001040 **RSC50 H**
~~£ 14,450.00~~ **£ 7,230.00**

Workshop equipment combination RSC50

Combination comprising:

- 1 2.240 mm worktop (RSC50 PG/3-2,2MT)
- 1 fixed service module with 2 drawers (RSC50 MS-2C)
- 1 mobile roller cab with 7 drawers (RSC50 C7)
- 1 fixed module with 7 drawers (RSC50 M7)
- 1 fixed module with built-in sink (RSC50 ML)

- 4 wall-mounted cabinets (RSC50 PM)
- 4 upper perforated tool panels (RSC50 PFS)
- 4 lower perforated tool panels (RSC50 PFI)
- 4 pairs of right/left uprights (RSC50 P/2MDX-SX)
- 1 single-door cabinet (RSC50 A1)



050001030 **RSC50 F**
~~£ 11,920.00~~ **£ 5,960.00**

Workshop equipment combination RSC50

Combination comprising:

- 1 2.240 mm worktop (RSC50 PG/3-2,2MT)
- 1 fixed module with 7 drawers (RSC50 M7)
- 1 mobile roller cab with 7 drawers (RSC50 C7)
- 1 fixed service module with 2 drawers (RSC50 MS-2C)
- 3 wall-mounted cabinets (RSC50 PM)
- 3 upper perforated tool panels (RSC50 PFS)
- 3 lower perforated tool panels (RSC50 PFI)
- 3 pairs of right/left uprights (RSC50 P/2MDX-SX)
- 1 two-door cabinet (RSC50 A2)



050001020 **RSC50 D**
~~£ 7,520.00~~ **£ 3,760.00**

Workshop equipment combination RSC50

Combination comprising:

- 1 1.495mm worktop (RSC50 PG/2-1,5MT)
- 1 fixed module with 5 drawers (RSC50 M5)
- 1 fixed two-door module (RSC50 MA)
- 2 wall-mounted cabinets (RSC50 PM)
- 2 upper perforated tool panels (RSC50 PFS)
- 2 lower perforated tool panels (RSC50 PFI)
- 2 pairs of right/left uprights (RSC50 P/2MDX-SX)
- 1 single-door cabinet (RSC50 A1)



RSC24AXLP/7

Mobile roller cab with 7 drawers, with wood worktop and anti-tilt system, long model

Long model with 7 fully removable drawers (882x367 mm), with ball bearing slides:

- 5 drawers, 70 mm high
- 1 drawer, 140 mm high
- 1 drawer, 210 mm high
- Multi-ply wood worktop with holes for a vice 1599F/100 or 1599GI/100 (to be ordered separately)
- Sturdy nylon front, with built-in label holder
- Drawer bases protected by foamed rubber mats
- 4 castors, Ø 125 mm: 2 fixed and 2 steering (one with brake)
- Front centralized safety lock
- Static load capacity: 1.100 kg
- Built-in side bottle holder (can be applied on both sides)
- Built-in paper roll holder
- Each drawer can accommodate up to 6 EVA foam or ABS thermoformed trays

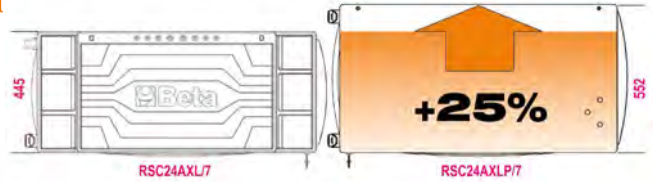

Ral 2011	Ral 7016	Ral 3000
024004571	024004577	024004573

£ 2,030.00 **£ 1,020.00**

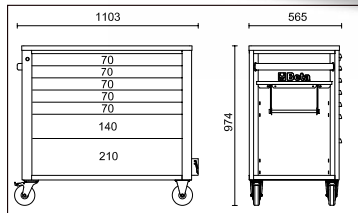

n°	Height	Max Weight
5	70 mm	30 kg
1	140 mm	35 kg
1	210 mm	35 kg

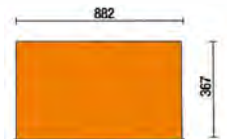

Following accessories can be added:

024004992

2400 RSC24AXLP/PF

£ 143.00 **£ 70.00**

Perforated tool panel with supports, for roller cab RSC24AXLP/7



024004995

2400 RSC24AXLP/VL

£ 61.00 **£ 30.00**

Side tool tray for roller cab RSC24AXLP/7



024004900

2400 RSC24/MP

£ 120.00 **£ 60.00**

Folding shelf for mobile roller cab RSC24AXLP/7



024004909

2400 RSC24/SPC

£ 213.00 **£ 110.00**

Computer bracket for mobile roller cab RSC24AXLP/7



024004993

2400 RSC24AXLP/CPR

£ 78.00 **£ 40.00**

Waste bin for roller cab RSC24AXLP/7



088880443 **CPMB/3C**

~~£ 61.00~~ **£ 30.00**

Workbench small parts containers with 3 drawers

- Outer frame made of PP
- Small parts drawers made of PET
- Stackable
- Interior drawer dimensions: 160x107x105h mm



600x155x175 mm

2 kg

Specifications of drawers:

- Unbreakable
- Glass effect transparency unchanged over time
- Scratchproof
- Resistant to oil, acids and aggressive chemicals
 - Also suitable for use in food products

088880445 **CPMB/5C**

~~£ 73.00~~ **£ 40.00**

Workbench small parts containers with 5 drawers

- Outer frame made of PP
- Small parts drawers made of PET
- Stackable
- Interior drawer dimensions: 90x86x62h mm



600x133x132 mm

1,5 kg

088880453 **KIT 6VC/3C**

~~£ 33.50~~ **£ 20.00**

Kit of 6 removable trays for small parts containers CPMB/3C

6x



088880455 **KIT 10VC/5C**

~~£ 31.50~~ **£ 20.00**

Kit of 10 removable trays for small parts containers CPMB/5C

10x



021090200 **C9MT**

~~£ 112.00~~ **£ 60.00**

Maintenance tool bag, empty

- Sturdy PVC cover, waterproof
- Reinforcement seams around the entire perimeter
- Double clip buckle closure
- Double interior handle for a safe, balanced hold
- Zipped document pocket



450x180x200 mm

1,4 kg

021091026 **2109MT ID/1**

~~£ 802.00~~ **£ 400.00**

Maintenance tool bag C9MT with assortment of 24 plumbing tools

24x

Beta N Description

- 111E 1 Adjustable wrench 250 mm
- 332/2 1 Mini pipe cutter for copper and light alloy pipes Ø 3÷28 mm
- 334 1 Pipe cutter for copper and light alloy pipes Ø 3÷30 mm
- 342 1 Ratchet-type shears for plastic pipes Ø 0÷42 mm
- 345SB2 1 Deburrer with fixed blade 140 mm
- 376 2 Pipe wrenches, Swedish pattern, 90° flat jaws 320-410 mm
- 1048N 2 Slip joint pliers, slip-proof PVC coated handles 175-250 mm
- 1128BMX 1 Electrician's scissors, straight blades
- 1150GBM 1 Heavy duty combination pliers, bi-material handles, industrial finish = 180 mm
- 1201E 4 Screwdriver for slotted head screws ● 3x75-4x100-5,5x150-8x150 mm
- 1202E 2 Screwdriver for cross head Phillips® screws ● PH1x80-PH2x100
- 1370 1 Engineer's hammer 500 g
- 1690F 1 Folding ruler made of fibreglass 2 m
- 1692/5 1 Measuring tape 5 m
- 1696 1 Spirit level, made of aluminium 200 mm
- 1719BMA...M 1 Second-cut half-round files 200 mm
- 1719BM/RL 1 Flat rasp file, plastic handle 200 mm
- 1725 1 Hacksaw frame, aluminium handle



// 666 ZERO-RESET

THE NEW TORQUE WRENCH THAT DOES NOT REQUIRE RELEASING TENSION.

Even if tension is not released, the number of cycles, durability and tightening accuracy as required by reference standards are guaranteed. In order to confirm these parameters, Beta Utensili's Research & Development Department performed numerous durability tests at the in-house laboratories as at hundreds of end users'. This result has been obtained through:

- the use of the best-performing currently available materials;
- special heat treatments on interior parts.

Based on the new parts, the wrench no longer has to be reset to the minimum value at the end of the operation cycle.

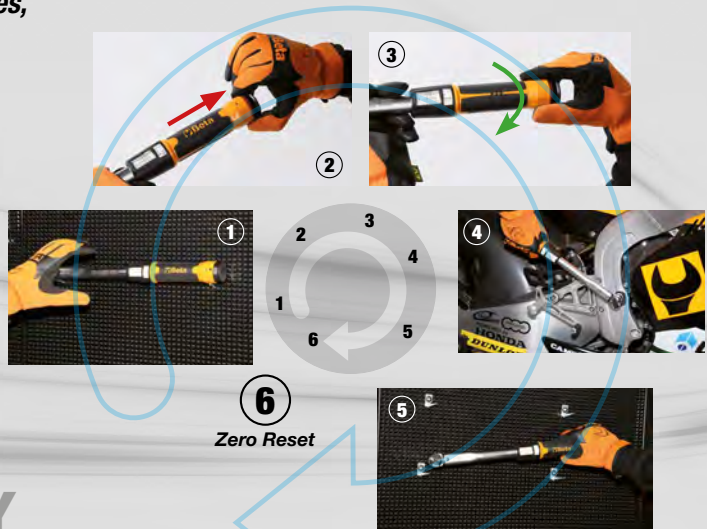

100% MADE IN ITALY

The Zero-Reset torque wrench was entirely designed and developed in-house and is manufactured at Beta Utensili's factories in Italy, using 100% Italian-made parts.



Click-type torque wrench for right-hand tightening

// 666 // 666 LBF.FT

Scale in lbf.ft

The wrench that does not require releasing tension after use. 100% Italian-made, it is ideal for controlled tightening of screws/bolts. The innovative Zero-Reset torque wrench is fitted with a reversible ratchet for right-hand tightening; torque accuracy: $\pm 3\%$. Reaching the set torque is indicated by a mechanical click that can be heard and touched.

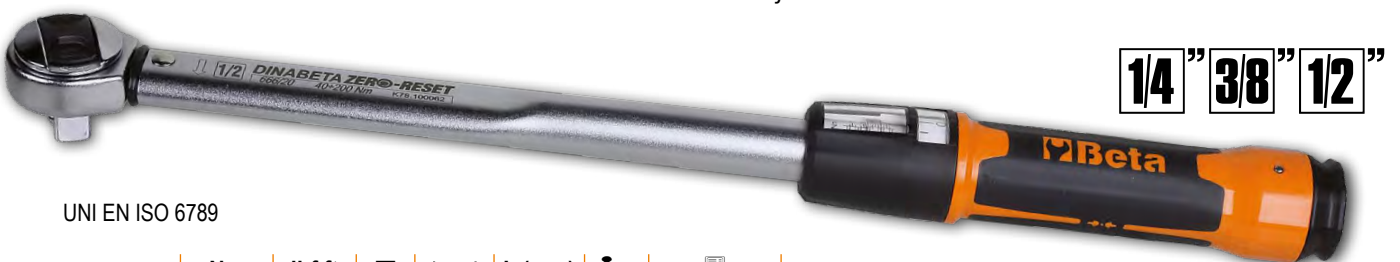

UNI EN ISO 6789

	Nm	lbf.ft	■	▤	L (mm)	g			
666/2	5÷25		1/4	0,05	273	395	006660702	£ 286.00	£ 140.00
666/2X	5÷25		3/8	0,05	273	405	006660703	£ 286.00	£ 140.00
666/5	10÷50		3/8	0,25	342	680	006660705	£ 256.00	£ 130.00
666/10	20÷100		3/8	0,25	385	760	006660710	£ 258.00	£ 130.00
666/10X	20÷100		1/2	0,25	385	770	006660711	£ 260.00	£ 130.00
666/20	40÷200		1/2	0,5	471	1020	006660720	£ 286.00	£ 140.00
666/30	60÷300		1/2	1	600	1270	006660730	£ 331.00	£ 170.00
666-LBF.FT/2		4÷18	1/4	0,05	273	395	006660762	£ 286.00	£ 140.00
666-LBF.FT/2X		4÷18	3/8	0,05	273	405	006660763	£ 286.00	£ 140.00
666-LBF.FT/5		7÷37	3/8	0,25	342	680	006660765	£ 256.00	£ 130.00
666-LBF.FT/10		15÷75	3/8	0,25	385	760	006660780	£ 258.00	£ 130.00
666-LBF.FT/10X		15÷75	1/2	0,25	385	770	006660781	£ 260.00	£ 130.00
666-LBF.FT/20		30÷150	1/2	0,5	471	1020	006660782	£ 286.00	£ 140.00
666-LBF.FT/30		50÷230	1/2	1	600	1270	006660783	£ 331.00	£ 170.00

ZERO-RESET TECHNOLOGY: Based on higher-performance materials and improved heat treatment of both the spring and the component parts of the adjustment system, the wrench no longer requires releasing tension after use. **EASY SETTINGS:** The graduated scale allows minimum interval fractions to be set up (in tenths of Nm/lbf.ft). **IMPROVED VISIBILITY:** Double graduation for clearer, simpler torque visibility.



316x254x96 mm

2,3 kg

019720112 **1972/K12V-10**
~~£ 288.00~~ **£ 140.00**

Ultracompact drill, 12V

Ultracompact: no more than 170 mm in length;

Ultralightweight: no more than 1.1 kg, with battery, and **perfectly balanced**

Features:

- Double mechanical speed with steel gears and 20-position clutch
- Torque up to 30 Nm and 1300 rpm (400 rpm in 1st gear); drills diameters up to 10 mm in steel and 20 mm in wood
- 2Ah batteries and charge indicator on drill body
- Ergonomic nonslip handle
- Front LED
- 10-mm self-locking chuck
- Belt clip (right/left side)
- Selector switch, screwing-unscrewing-locking modes (for transportation)
- **Supplied in a hard case with 2 lithium ion batteries (2 Ah) and quick charger (50 min)**



Beta
3-YEAR
WARRANTY



316x254x96 mm

2,3 kg

019820112 **1982/K12V**
~~£ 288.00~~ **£ 140.00**

Reversible impact wrench, 12V,

ideal for jobs in small areas, provides high torque (80 Nm), one-handed operation

Ultracompact: no more than 160 mm in length;

Ultralightweight: no more than 1 kg, with battery, and **perfectly balanced**

Features:

- 1/4" hexagon drive with locknut
- Belt clip (right/left side)
- Front LED
- Selector switch, screwing-unscrewing-locking modes (for transportation)
- Ergonomic nonslip handle
- Gearcase made entirely of metal
- 2Ah batteries with charge indicator on impact wrench body
- **Supplied in a hard case with 2 lithium ion batteries (2 Ah) and quick charger (50 min)**



Beta
3-YEAR
WARRANTY



310x295x100 mm

3 kg

019720010 **1972/K12V-COMBO**
~~£ 488.00~~ **£ 240.00**

12V kit of ultracompact drill + 1/4" HEX reversible impact wrench

Case contents:

- 1x12V ultracompact drill, with 10-mm autochuck
- 1x12V reversible impact wrench, with 1/4" hexagon drive
- 2x2Ah lithium ion batteries
- 1 quick battery charger



Beta
3-YEAR
WARRANTY

ROBUR's permanent magnetic lifters stand out as compact, sturdy, reliable machines; they are widely used in factories, warehouses, harbour quays and transportation facilities. Designed in compliance with EN13155, this equipment is suitable for lifting and handling magnetic iron materials, including dies, sheet metal, pipes, fittings, beams and bars.

The permanent magnet is made from a Neodymium-Iron-Boron alloy, which has an extremely high attractive force and is defined as "super magnetic". Since magnetic lifters require no voltage, they can also be used in places where no power connection is available. One operator can easily lift, transport and release the load through the operating lever: when the lever is moved into the ON position, a spring mechanism will lock it, keeping the magnet active and preventing accidental release.

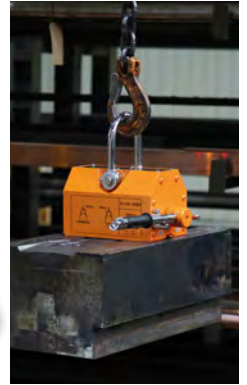

8134

Robur

Permanent magnetic lifters

Technical data:

- Safety factor: 3
- Identification tag with serial number

Available certificates:

- Manufacturer's Certificate
- Declaration of Conformity with Machinery Directive 2006/42/EC
- Test Report UNI EN10204 type 2.2
- Operation and maintenance manual

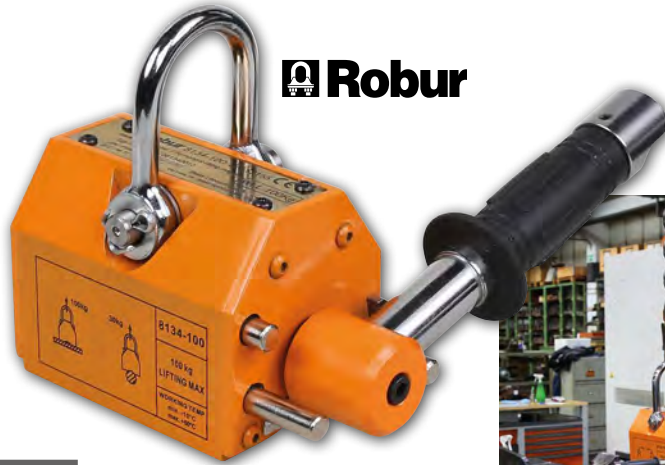

£

8134 100 KG	081340010	£ 540.00	£ 270.00
8134 300 KG	081340030	£ 950.00	£ 480.00
8134 600 KG	081340060	£ 1,770.00	£ 890.00
8134 1000 KG	081340100	£ 2,920.00	£ 1,460.00

018600680 1860BHT/KT

~~£ 1,270.00~~ **£ 640.00**

DC-output welding machine kit, for MMA and TIG electrode welding, TIG welding torch included

Arc force, hot start, anti-sticking and thermostatic protection features.



Supplied with 25 mm² cables



Adjustment current	10÷160A
Power supply	1x230V
Use factor (40 °C)	35% - 160 A
	60% - 130 A
	100% - 95 A
Protection	IP23S
Usable electrodes	Ø 1,6 - 4 mm rutilic, basic, stainless steel
Dimensions	360x140x230 mm
Welding machine weight	6,2 kg
Torch length	4 m



007200634 **720RNG**

~~£ 24.00~~ **£ 10.00**

Impact socket for Jeep Renegade wheel nuts with aluminium damaged caps

Required when nut caps are damaged by impact wrenches

12"



⊙ 16.5 mm - 17.5 mm

009600218 **960PI/K36**

~~£ 239.00~~ **£ 120.00**

Kit of brushes for cleaning injector seats

Kit contents:

- 12 nylon brushes, 8÷19 mm (1 mm interval)
- 12 steel brushes, 8÷19 mm (1 mm interval)
- 12 brass brushes, 8÷19 mm (1 mm interval)
- 1 bit holder with quick coupling and magnetic bottom
- 1 extension with quick coupling and magnetic bottom



≡ 350x255x74 mm

1,2 kg

013640005 **1364SR**

~~£ 295.00~~ **£ 150.00**

Wheeled dispenser for masking paper rolls

Specifications:

- with 2 handling wheels
- 3 paper roll bars with built-in paper cutting blade
- built-in paper tape support
- max. paper roll dimensions: 350 - 650 - 1050 mm



013660400 **1366SH**

~~£ 2,510.00~~ **£ 1,260.00**



Multifunction bodywork spotter

- Microprocessor for managing welding parameters
- Contact and manual welding cycle start
- Automatic spot welding time setting function
- Supplied with quick coupling gun and 2.2 m long ground cable

Accessory kit contents:

- extractor hammer
- three-pointed washer head
- 10 three-pointed washers
- carbon electrode
- squashing electrode



kg 23



Power supply:	230V
50% power:	2.5 KVA
Power peak:	13 KVA
Amp output:	2850 (2%) A
Max. Amp output:	3200 A

013660410 **1366SH/C**

~~£ 491.00~~ **£ 250.00**

Trolley for spotter 1366SH



018770180 **1877P**

~~£ 540.00~~ **£ 270.00**

Exhausted oil drain unit, wheeled, with polyethylene tank

- Tank capacity: 40 l
- Large oil pan made of PP
- Level indicator
- Pneumatic drum emptying



030250111 **3025N/PF**

~~£ 565.00~~ **£ 280.00**

Barrel handling clamps

Maximum capacity:
300 kg



030250110 **3025N 1,0**

~~£ 2,680.00~~ **£ 1,340.00**

Folding hydraulic crane with dual effect pump

Specifications:

- maximum capacity: 1 t
- 4 loading positions: 300-600-800-1000 kg
- with load limiting valve and chrome-plated stand
- controlled descent speed
- nylon wheels
- maximum height: 2420 mm

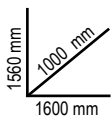

030270101 **3027N 10**

~~£ 2,240.00~~ **£ 1,120.00**

Hydraulic bench press with moving piston

- Maximum capacity: 10 t
- Manual 2-speed pump
- Moving piston
- Automatic piston return
- Set of V-shaped prisms included
- Chrome-plated stand

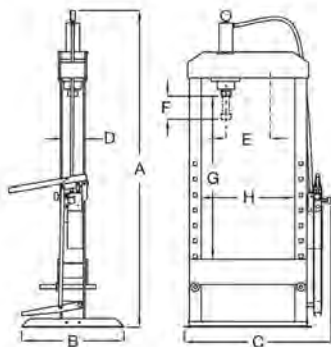

3027N 10	
A	1030
B	500
C	830
D	125
E	310
F	150
G	330
H	530



030270102 **3027N 20**

~~£ 3,030.00~~ **£ 1,520.00**

Hydraulic press with moving piston

- Maximum capacity: 20 t
- Manual 2-speed pump
- Moving piston
- Chrome-plated stand
- Automatic piston return
- Hydraulic overloading safety device
- Gauge
- Set of V-shaped prisms included

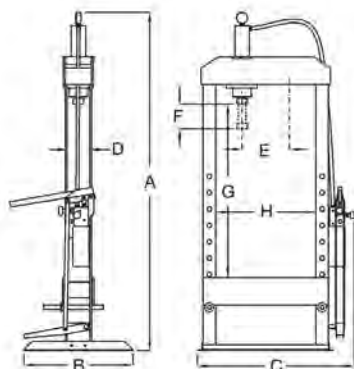

3027N 20	
A	1870
B	600
C	920
D	125
E	310
F	150
G	1000
H	580



030270103 **3027N 30**
~~£ 5,490.00~~ **£ 2,750.00**

Hydraulic press with moving piston and hoist

- Maximum capacity: 30 t
- Manual 2-speed pump
- Moving piston
- Chrome-plated stand
- Automatic piston return
- Hydraulic overloading safety device
- Gauge
- Steel rope hoist for lifting worktop

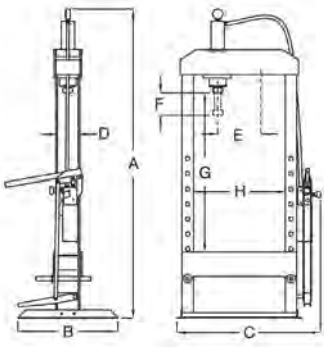

3027N 30	
A	2110
B	600
C	1140
D	160
E	340
F	150
G	1150
H	700



030270105 **3027N 50**
~~£ 7,700.00~~ **£ 3,850.00**

Hydraulic press with moving piston and hoist

- Maximum capacity: 50 t
- Manual 2-speed pump
- Moving piston
- Chrome-plated stand
- Automatic piston return
- Hydraulic overloading safety device
- Gauge
- Set of V-shaped prisms
- Steel rope hoist for lifting worktop

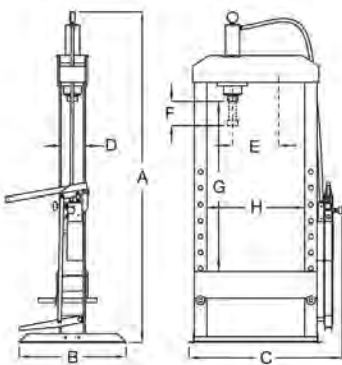

3027N 50	
A	2100
B	750
C	1350
D	230
E	480
F	165
G	1000
H	790



030280015 **3028 15**

£ 1,320.00 **£ 660.00**



Hydraulic bench press with moving piston

Features:

- maximum capacity: 15 t
- manual vertical top adjustment
- sliding piston
- hydraulic overloading safety device
- gauge
- set of V-shaped prisms included

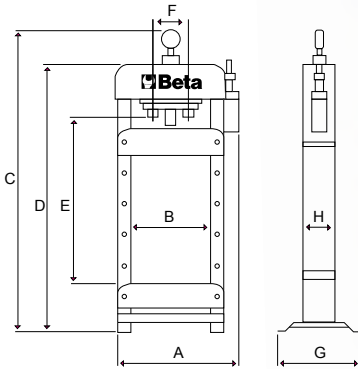

3028 15	
A	678
B	440
C	1015
D	850
E	390
F	240
H	134
G	480

57 kg



030280016 **3028SP/15**

£ 191.00 **£ 100.00**

Protective screen for press 3028 15

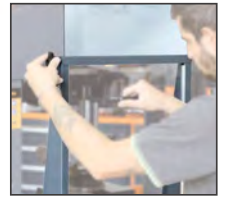

030080110 **3008N**

£ 4,050.00 **£ 2,030.00**



Jack and positioner for single and twin truck wheels

- Maximum capacity: 500 kg
- Minimum height: 120 mm
- Maximum height: 650 mm
- Distance between rollers: 429÷670 mm
- Hydraulic overloading safety device
- Front pivoting wheels

3008N	
A	1200
B	940
C	120
D	500
E	1030
F	429-670

130 kg

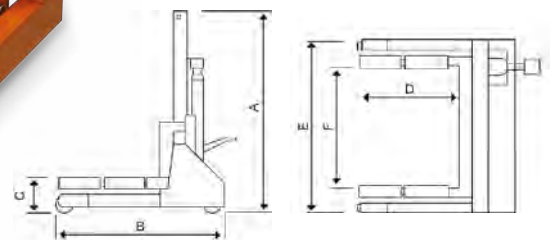



7819G

~~£ 86.00~~

£ 40.00

Work trousers, multipocket style, with detachable flying pockets,

T/C canvas, 260 g/m², grey

Knee pad pockets and leg bottoms reinforced in polyester 300D, tearproof crotch and stretch fabric inserts in inside legs and lumbar region for easier movements

CONVENIENCE Trousers designed to provide unique convenience, based on the 14 pockets. The accurate details, detachable pockets at waist and ruler pockets ensure unique convenience, even for the most demanding workers.

STRENGTH The polyester and cotton fabric is synonymous with hard-wearing trousers. The addition of anti-abrasion inserts on the knees and leg bottoms translates into further increased strength.

COMFORT The addition of stretch inserts in inside legs and on the back results in remarkably comfortable trousers.



XS	46	078190000
S	48	078190001
M	50	078190002
L	52	078190003
XL	54	078190004
XXL	56	078190005
XXXL	58	078190006

7850G

~~£ 60.00~~

£ 30.00

Cargo work trousers,

100% cotton, 240 g/m², stretch waistband on sides and large side pockets with reflex inserts, grey with fluorescent green detail slim fit

Beta's "cargo" work trousers are the name for a modern, simple solution, for those who prioritize comfort, without compromising style.

CLASSIC, THOUGH FASHIONABLE LOOK Simple, essential lines and attention to detail make these trousers ideal for both work and free time.

COMFORT The fabric made of 100% cotton and the stretch waistband have been specially designed to provide unparalleled convenience and comfort in all working situations.

CONVENIENCE Special attention to the choice and positions of the pockets results in slim yet extremely practical trousers.



XS	46	078500100
S	48	078500101
M	50	078500102
L	52	078500103
XL	54	078500104
XXL	56	078500105
XXXL	58	078500106
XXXXL	60	078500107

7636N

~~£ 31.50~~ **£ 20.00**

Microfleece sweater, short-zipped, 180 g/m² black with reflex details

This microfleece sweater combines a simple style with comfort and convenience.

SIMPLE, ESSENTIAL LINES The black colour and the reflex details result in a simple style, allowing this sweater to match any garment of Beta's range.

COMFORT AND PROTECTION The extremely lightweight fleece fabric results in a remarkably comfortable and slim garment for work, without compromising cold protection.



XS	076360500
S	076360501
M	076360502
L	076360503
XL	076360504
XXL	076360505
XXXL	076360506

7642G

~~£ 38.50~~ **£ 20.00**

Crew-neck sweatshirt, 240 g/m², 60% cotton, 40% polyester, melange grey, black inserts

Beta's crew-neck sweatshirt is the perfect combination between comfort and a modern look.

COMFORT The soft, warm fabric ensures unique comfort during work. The stretch ribbed neck, cuffs and bottom result in an even more practical and functional garment.

MODERN LOOK The fluorescent details as well as the coloured seams and the reflex inserts provide a touch of uniqueness and style.



XS	076420000
S	076420001
M	076420002
L	076420003
XL	076420004
XXL	076420005
XXXL	076420006

7750N

~~£ 95.00~~ **£ 50.00**

Work bomber jacket, multipocket style, 100% polyester, 100% polyester padding, 120 g/m², black

Work bomber jacket synonymous with strength and convenience in all working situations.

PROTECTION The 100% polyester fabric and padding are the name for remarkable strength and cold protection in a simple, yet functional garment.

CONVENIENCE The two chest pockets and the waist pockets with zip closure mean an optimal solution translating into a practical, functional garment.

CUSTOMIZATION The interior pocket allows for a fully customized garment.



XS	077500000
S	077500001
M	077500002
L	077500003
XL	077500004
XXL	077500005
XXXL	077500006
XXXXL	077500007

7981N
~~£ 27.00~~ **£ 10.00**
Rainproof cap

- 100% PU-coated nylon
- Water-repellent treatment
- Lined with breathable fabric
- Reflex band on back
- Front reflex logo
- Black

58	079810158
60	079810160

~~£ 15.50~~ **£ 10.00**
Microfleece neck warmer with string adjuster

 100% polyester microfleece, 180 g/m²

- Stretch string adjuster
- Side outline logo
- Side reflex band
- Black with grey and reflex details
- **One size fits all**

7980RN
~~£ 15.50~~ **£ 10.00**
Cuffed winter cap, one size only

- 100% acrylic
- Lined with 3M Thinsulate™
- Ribbed fabric
- Cuff height: 8 cm
- Front patch with logo
- Black
- **One size fits all**

7422P
~~£ 18.00~~ **£ 10.00**
2 pairs of calf-length socks made from recycled terry cotton

39/42	074220102
43/46	074220104



45% cotton, 45% polyester, 7% polyamide, 3% elastane

- Leg height from heel centre: 20 cm
- 3-cm-high cuffs
- 17-cm-high ribbed legs
- Toe and heel areas made from tremor-effect terry cotton

- **2 pair pack**
- Black with grey, orange and brown inserts
- Grey with black, orange and brown inserts

7426P
~~£ 17.00~~ **£ 10.00**
2 pairs of maxi sneaker socks made from cotton with terry cotton in sole area

39/42	074260102
43/46	074260104



45% cotton, 45% polyester, 7% polyamide, 3% elastane

- 3-cm-high ribbed cuffs
- Leg height from heel centre: 7 cm
- Sole area made from terry cotton
- Toe and heel areas made from tremor-effect terry cotton

- **2 pair pack**
- Grey with black and electric blue inserts
- Black with electric blue and grey inserts

7430T
~~£ 21.50~~ **£ 10.00**
3 pairs of sneaker socks made from recycled cotton

39/42	074300202
43/46	074300204



45% cotton, 45% polyester, 7% polyamide, 3% elastane

- Leg height from heel centre: 2.5 cm
- 3-cm-high cuffs
- Toe and heel areas made from tremor-effect terry cotton

- **3 pair pack**
- Melange grey with black and bordeaux inserts
- Melange grey with black inserts
- Black with grey inserts

Beta

Fabio Quartararo
2023 MotoGP
World Championship



Partnership 2023



99804711

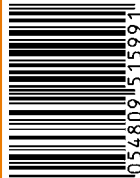

8 0548091515991

Beta Tools (UK) Limited | Unit D - Horton Enterprise Park
Hortonwood 50, Telford | Shropshire, TF1 7GZ
Sales: Tel. (01952) 677977

www.beta-tools.co.uk | sales@beta-tools.com

The images are for reference only. Beta Utensili S.p.A. reserves the right to update and upgrade its product range without notice.